

Enabling Dynamic Spectrum Access using SS-MC-CDMA

Sarath, D., Nolan, K.E., Sutton, P.D., Doyle L.E.

Centre for Telecommunications Value-Chain Research (CTVR)

Trinity College Dublin

Rep. of Ireland

Email: sarathd@tcd.ie, keithnolan@mee.tcd.ie, suttonpd@tcd.ie, ledoyle@tcd.ie

Abstract—The demand for frequency spectrum and diversity of wireless devices accessing this spectrum depends upon the time of day, the characteristics of a frequency band, and the geographical location of the observer/wireless device. This paper highlights the value of employing a novel dynamic spectrum access technology using a highly reconfigurable spectrum access scheme with excellent frequency diversity properties. We name this robust scheme selective subcarrier multi-carrier code division multiple access (SS-MC-CDMA).

This paper contains three main contributions. Firstly, the reconfigurability options in a physical layer (PHY) using MC-CDMA and the flexibility in system design of a cognitive radio are presented. Secondly, an application of the novel SS-MC-CDMA system in a dynamic spectrum access (DSA) scenario is developed in order to indicate the value and potential of this system. Finally, based on this scenario, we present some initial key results from both simulation and real-world experiments.

I. INTRODUCTION

The demand for frequency spectrum can be dependent on the time of day, desired frequency characteristics e.g. line of sight/non line of sight capability, and the location of the wireless device or network. In order to help cope with the ever-increasing demand for this resource, the development of practical and robust spectrum sharing techniques involving primary licensed incumbents and secondary opportunistic spectrum users is vital. The combination of an agile spectrum access and multiplex system combined with the awareness, decision-making, and learning abilities of a cognitive radio offer a viable solution to help accomplish this objective. This paper focuses on the opportunities that a novel highly reconfigurable spectrum access scheme with excellent frequency diversity properties can offer in this context.

Dynamic spectrum access (DSA) techniques aim to exploit the under-utilized frequency spectrum by employing new advancements in the field of spectrum sharing and opportunistic access. Secondary opportunistic users would have the potential to exploit unused or underused frequency bands allocated to primary users. The development of cognitive functionality in wireless communications systems has made the realisation of these concepts possible. Cognitive radio (CR) can be described as a node in a network with the abilities to form an awareness of its environment and context, make decisions and inferences from this information combined with knowledge of the user's

objectives. In addition, a CR can act in a manner that attempts to accomplish the user's objectives, and learn from these experiences for possible use in the future [1].

This paper primarily focuses on the PHY layer issues. At this layer, multi-carrier spectrum access techniques including orthogonal frequency division multiplexing (OFDM) and multi-carrier code division multiple access (MC-CDMA) offer a number of significant advantages over single-carrier (SC) systems in volatile wireless channel environments. Multi-carrier systems are inherently more resilient to the effects of inter-symbol-interference (ISI) and multi-path fading [2]. In addition, the spectral efficiency is higher than SC systems due to the closely-packed carriers. Received signals can be equalised in the frequency domain, which reduces the complexity of this stage compared to time-domain equalisation techniques.

MC-CDMA has emerged as a feasible alternative to OFDM for forward-looking multi-carrier communications systems [3]–[6] by exploiting the flexibility and potential offered by the combination of OFDM and CDMA. In conjunction with the cognitive capabilities of the node, we can choose the subcarriers for allocating data, resulting in the novel SS-MC-CDMA system. We highlight the reconfigurability options of MC-CDMA systems and their variants in a CR scenario in [7]. This paper builds on this work to present and analyse a novel application of SS-MC-CDMA in a practical DSA scenario.

Section II presents a brief explanation of a MC-CDMA transceiver, highlights the various reconfigurability options on adopting a CR approach and introduces our SS-MC-CDMA system. Section III details an application of SS-MC-CDMA and illustrates its scope in DSA. Section IV presents some of the key experimental results related to this scenario and highlights a real test scenario. Section V points out the scope for future research and concludes.

II. MULTI-CARRIER CDMA AND SS-MC-CDMA

A. Multi-carrier CDMA (MC-CDMA)

MC-CDMA is an OFDM-based multiple-access spread-spectrum scheme. By combining frequency domain and time domain dispersal of modulated symbols, two main variants of

multi-carrier spread spectrum systems, the MC-CDMA and MC direct sequence CDMA (MC-DS-CDMA) can be obtained. In MC-CDMA, each symbol is spread using code chips and transmitted on several subcarriers. MC-DS-CDMA differs in the fact that the data is spread in the time domain rather than in the frequency domain. Thus the MC-CDMA system exploits frequency diversity whereas the MC-DS-CDMA exploits time diversity.

An extensive study of MC-DS-CDMA and its comparison with MC-CDMA can be found in [5], [6]. The *M-Modification* of MC-CDMA [2] has been adopted for the initial implementation in our system. The M-implementation of MC-CDMA incorporates the concept that the spreading length need not necessarily be equal to the number of subcarriers. As shown in Fig.1, M symbols of each user are transmitted in parallel. In the context of the paper, unless specified otherwise, MC-CDMA referred to is the M-Modification of the multi-carrier CDMA with code assisted spreading in the frequency domain.

Subcarrier symbol multiplexing can be performed efficiently using the inverse fast Fourier transform (IFFT) and the FFT procedure is used for subcarrier symbol de-multiplexing. The transmitter side operation of MC-CDMA, as demonstrated in Fig. 1, consists of the addition of a cyclic prefix (CP) to mitigate the effects of intersymbol interference (ISI), the OFDM frame formation and parallel to serial conversion. The CP length is chosen such that it is greater than the delay spread of the channel so that the effects of multi-path are mitigated effectively. The hardware front end follows where digital to analog conversion (DAC) takes place and the signal is upconverted and transmitted on the required frequency channel. At the receiver side, the reverse operation takes place with ADC, serial to parallel conversion, removal of CP, extraction of symbols from the frame, code de-spreading and detection.

Consider the code of user k having length n as shown; where c_n represents the chips of the individual code.

$$C^k = \{c_1^k, c_2^k, c_3^k, c_4^k, \dots, c_n^k\} \quad (1)$$

For K users transmitting simultaneously using n -length orthogonal codes on N_{fft} subcarriers, the system can be represented as shown in Fig. 1. If there are M data symbols before spreading, assuming all the subcarriers are filled by spread data, the condition is that

$$N_{fft} = M \times n. \quad (2)$$

In order to minimise the possibility of interference, the maximum number of users K_{max} should be equal to the code length n . Expanding on the basic MC-CDMA equation in [8], [9], we form an equation for the M-modification as shown in Fig. 2. Here, $S(t)$ denotes the complex envelope of an M-ary PSK modulated MC-CDMA signal and b_i denotes the M-ary PSK modulated data symbol from the stream r . The u^{th} chip of the n -length code of the k^{th} user is denoted by $c_{r,u}^k$ and the symbol period is T and $t \leq T$.

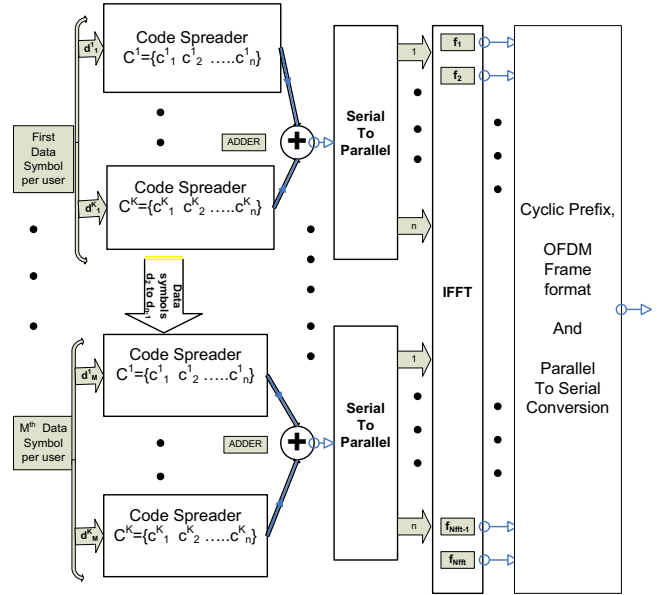

Fig. 1. Implemented M-Modification of MC-CDMA

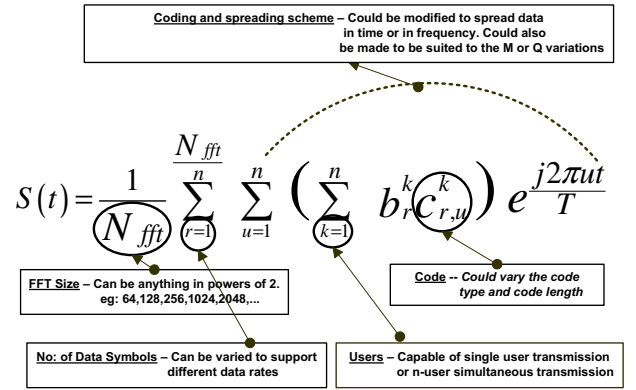

Fig. 2. Reconfigurability options and added flexibility in MC-CDMA

B. Flexibility in MC-CDMA

Our software radio approach to the implementation of MC-CDMA offers two main advantages. Firstly, it facilitates the reconfiguration of the MC-CDMA system and enables us to exploit its flexibility. Secondly, it allows the application of a cognitive approach where in the intelligent decisions of a CR is used to adapt the configurations and system parameters to yield the best performance. The reconfigurability options in MC-CDMA are illustrated in Fig. 2. Altering the coding block to accommodate spreading in time or frequency, we may generate the MC-CDMA or MC-DS-CDMA. We can also vary the different parameters such as coding length, the number of users and the FFT size. Increasing the code-length to the number of subcarriers result in the classic MC-CDMA system whereas reducing the code-length to one results in the typical OFDM system. The ability to switch from one MC-CDMA configuration to another with ease or operation of

hybrid modifications offers attractive advantages for dynamic adaptation and reconfigurability in a CR.

Cognitive functionality allows the system to dynamically choose the complexity of the pilots and synchronization preambles. If the cognitive engine indicates a hostile non-stationary channel, the pilots can be spread over several different subcarriers. Pilot symbols can also be spread in two-dimensions, i.e. frequency and time by distributing them over several OFDM symbols [10].

Equalization at the receiver side is necessary to counter the channel effects leading to the possible loss of orthogonality between the signals. Single-user detection (SUD) using linear equalizers such as maximum ratio combining (MRC) or equal gain combining (EGC), minimum mean square error (MMSE) or zero forcing (ZF); and multi-user detectors (MUD) using block equalizers are employed to achieve this [2], [5], [6]. When system parameters are known, techniques such as parallel or successive interference cancellation (PIC, SIC respectively) [2] can be utilized. Consider the case when an intelligent sensing mechanism informs the cognitive engine regarding the channel condition. Based on its learning process, it can predict the channel and employ pre-equalization techniques at the transmitter; thus offering a choice of complexity depending on the scenario.

In the case when the wireless communications channel is subject to deep fading, information may be lost. Under these circumstances, the frequency diversity offered by MC-CDMA is exploited to the maximum by interleaving the data before mapping it onto the subcarriers. 2-D interleaving [11] increases the diversity relative to time and frequency but at the expense of additional complexity and buffering, which makes it unsuitable for time-sensitive data.

We have illustrated that the various reconfigurability options in MC-CDMA are best exploited when a cognitive radio approach is adopted. It is also important to note that though it offers additional flexibility and reconfigurability, MC-CDMA suffers from issues related to high peak to average power ratios (PAPR), synchronization in both the time and frequency, dealing with carrier frequency offset and multiple access interference (MAI) [2], [5], [6], [12].

C. Selective Subcarrier MC-CDMA (SS-MC-CDMA)

SS-MC-CDMA system utilizes the intelligence mechanism of the CR to determine blank spaces in the spectrum and utilize them without interfering with the transmission of the primary user. Option of null subcarriers in MC-CDMA has been examined in [9] where its performance is compared with the performance of non-contiguous OFDM (NC-OFDM). In [9], MC-CDMA was found to be subject to a higher probability of error on nulling of subcarriers. The reason attributed to data loss in MC-CDMA was that the data in subcarriers are not *independent* as a result of the spreading operation. In our system, the data allocation to bins take place only after the subcarriers are selected. It is also important to note that the

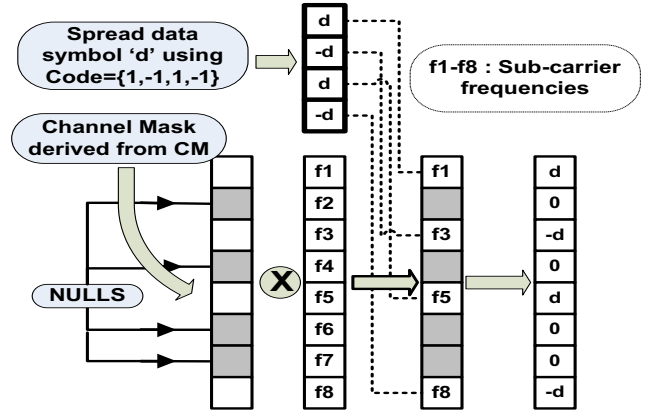

Fig. 3. Selective Subcarrier Allocation principle in SS-MC-CDMA

authors [9] assumed the classical MC-CDMA system with data spread on all subcarriers where as in an M-Modification of the MC-CDMA, the length of spreading code need not be equal to the number of subcarriers and thus it offers a lower dependency on the adjacent data.

In order to select the subcarriers, we would need the knowledge of the channel and details regarding spectrum occupancy. A *channel map* (CM) is a system parameter incorporated into the cognitive capabilities of the radio that provides details such as incumbent user information and the signal to noise ratio (SNR). Current research assumes the availability of this parameter whereas future work is focussed on developing the parameters analytically or by means of real measurements. These would also assist in identifying the *triggers* for the CR to switch from one configuration to other.

Based on the CM, a channel mask [13] is formed and the subcarriers which are either not occupied by primary users or not subject to deep fades are identified. These are filled by the spread data symbols and the others are nulled. The principle of selective subcarrier allocation is illustrated in Fig. 3. As is evident, there is a latency and overhead in identifying the subcarriers, selective nulling and allocation. In SS-MC-CDMA, there is the additional flexibility to allocate different subcarriers to different users or to superimpose several users' spread data on the same subcarriers using orthogonal codes.

III. APPLICATION OF SS-MC-CDMA TO DSA

Under a DSA scenario, the cognitive radio would need to sense the spectrum and choose available frequency bands. In cases where a frequency band is occupied by a narrowband user, the unoccupied part of the spectrum around the narrowband signal can be utilized by a secondary user. We have utilized SS-MC-CDMA with nulls in the center of the spectrum so that the transmission of the incumbent user is unaffected.

We have illustrated a conceptual application highlighting the possibilities of reconfiguration using SS-MC-CDMA and

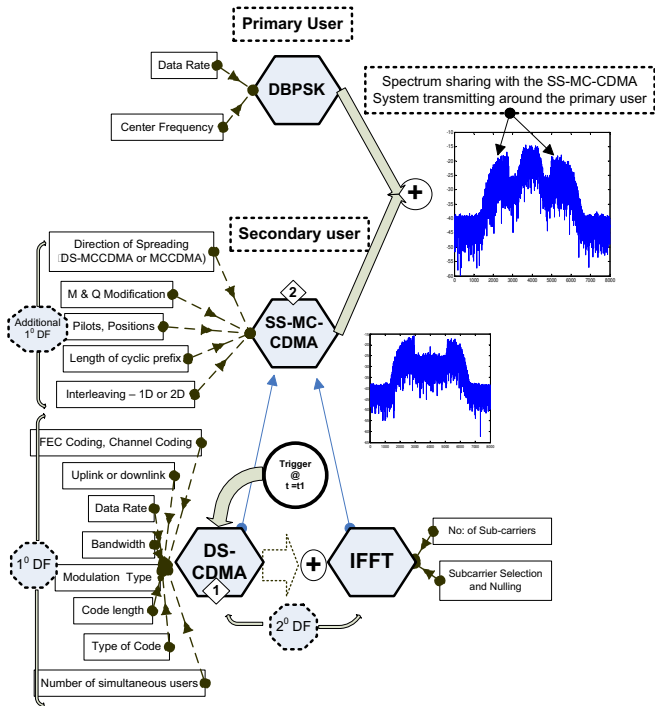

Fig. 4. Example of an Adaptation Cycle in DSA where the DS-CDMA secondary user adapts to become an SS-MC-CDMA system.

its application to DSA in Fig. 4. The levels of reconfiguration in MC-CDMA will be addressed as the primary degrees of freedom (1°DF) and secondary degrees of freedom (2°DF). 1°DF involves the parameters that are reconfigured almost instantly as reactions to triggers; such as the code type and length, FFT size, modulation method, channel coding and forward error correction (FEC). The secondary degrees of freedom, 2°DF , involve the configuration options that would lead to adaptation of the system as a whole. The advantage with this model is that the number of levels associated with each 1°DF and 2°DF can be varied and at a later stage, each of these manifests itself as one another. For example, when we consider a larger system, each block such as OFDM or MC-CDMA serves 1°DF whereas the whole system configuration such as WLAN, emergency networks and ad-hoc networks is the 2°DF .

Consider Fig. 4 where the primary user is a narrow-band DBPSK system. The initial state of the secondary user is DS-CDMA system. Upon sensing the opportunity to access the spectrum around the primary user, the CR uses CM to design the SS-MC-CDMA transmitter with nulls around the center frequency. In order to achieve this, it utilizes an IFFT block as well as a channel mask derived from the CM and initiates a trigger at time $t=t_1$. It determines the additional 1°DF parameters such as transmission power so as not to interfere with primary transmission. Note that the addition of new blocks offers the capability to modify not only the new 1°DF but also the inherited ones as well. At a later stage,

if the CM indicates a sufficiently good channel, the CR can default to an OFDM system by simply altering the coding length to one. In another scenario, as in OFDMA, we could allocate certain subcarriers to users by simply switching to the Q-modification [2] by altering the spreading block.

IV. SIMULATION AND TEST RESULTS

We have observed that contrary to the performance of classic MC-CDMA systems as shown in [9], upon nulling of subcarriers, the SS-MC-CDMA is not subject to greater probability of error. Performance improvement is realised over OFDM systems owing to the spreading of data, without which we would have lost information in case of deep channel fades or similar criteria. In order to illustrate this, we have simulated and tested the SS-MC-CDMA system under various criteria in Matlab and the results are presented. Channel estimation is performed using modified Chu sequences [16] and the channel is assumed to be stationary for the transmission period of the frame. We shall be illustrating the performance of QPSK systems under additive white gaussian noise (AWGN) channels and multipath rayleigh channel (Cost 207 Typical Urban Channel with 6 taps [17]).

Corresponding to Fig. 4, this is the scenario where a secondary user attempts to utilize the spectrum around the primary user by nulling the subcarriers. In Fig. 5, we can observe the effect of varying nulls in single user SS-MC-CDMA and its comparison with OFDM in an AWGN channel. We have assumed perfect time and frequency synchronization and have used SUD with MMSE equalisation at the receiver side. Simulations under multipath scenario are illustrated in Fig. 6. It can be observed in both the cases that there is a performance enhancement in single user SS-MC-CDMA scenario resulting from better frequency diversity on employing spreading.

When multiple users contend for the secondary access, the SS-MC-CDMA system enables the superimposing of data of several users by employing orthogonal codes. Under this scenario of multiple access, the simulation results are presented in Fig. 7 and Fig. 8. Under full load, we observe the effects of multiple access interference (MAI) which the SUD fail to mitigate. Research into MUD [2] has shown that it significantly reduces this interference at the expense of additional complexity. The degree of complexity, as explained in section II-B can be chosen by the CR to employ SUD, block linear equalizers or more complex techniques such as the PIC and SIC.

Simulations make it clear that applying variants of the MC-CDMA increases the agility and error-resilience of single-user reconfigurable systems in DSA systems. These variants of the classic MC-CDMA exploit the fact that in real systems, it might not be always necessary to spread the data into all the subcarriers. Understandably, if orthogonal codes are employed for spreading, the increased code length yields higher resilience to error. We can also identify that a SS-MC-CDMA system under full load with code length equal to the

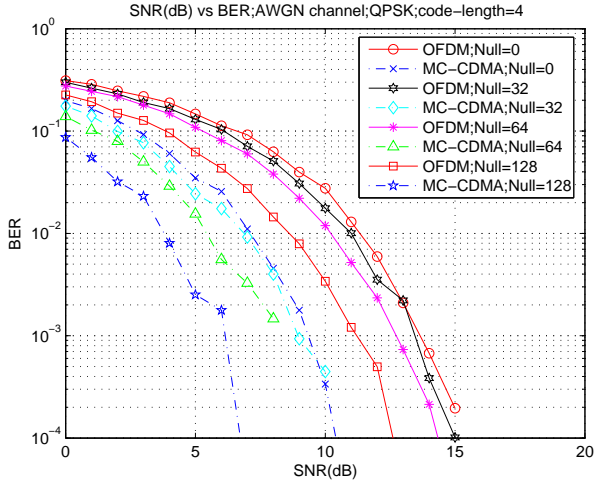

Fig. 5. Effect of subcarrier-nulling [AWGN channel]

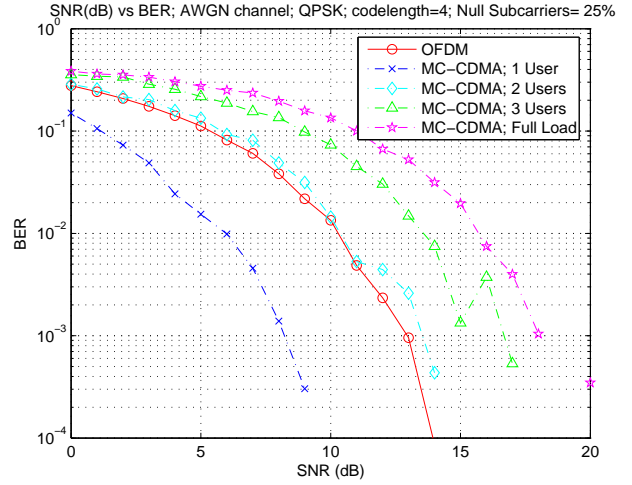

Fig. 7. Effect of subcarrier-nulling and number of users [AWGN channel]

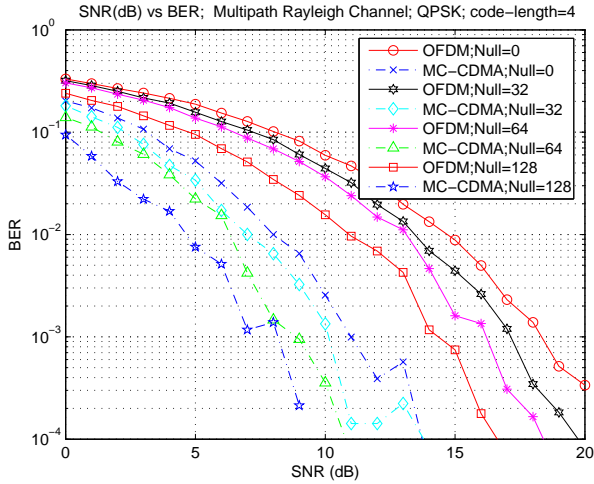

Fig. 6. Effect of subcarrier-nulling [COST 207 Typical Urban channel model]

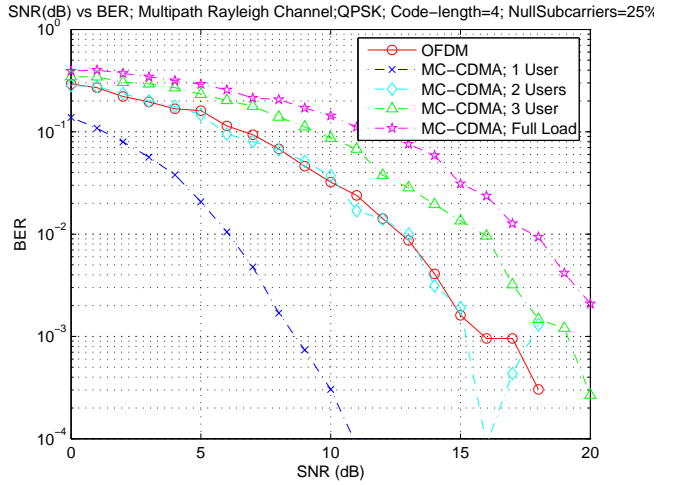

Fig. 8. Effect of subcarrier-nulling and number of users [COST 207 Typical Urban Multipath channel]

number of subcarriers is the classic MC-CDMA system. It is also to be noted that on employing SUD, the effects of MAI are not cancelled out and the performance deteriorates with increasing number of users. Since the performance of SUD in SS-MC-CDMA correlates with the performance of SUD in classic MC-CDMA, it can be inferred with reasonable assumption that their performance under MUD will also be similar i.e. we can expect a performance gain over SUD on employing MUD in SS-MC-CDMA. Future research will analyze the performance of fully-loaded SS-MC-CDMA using MUD and their implementation complexities will be studied. Non-contiguous MC-CDMA has also been examined in [18] where the effects of MAI are minimized by assigning each user's data to sets of non-contiguous subcarriers. Their principle of allocating sub-carrier sets can also be adopted to SS-MC-CDMA to mitigate the effects of MAI.

Fig. 9 illustrates the real scenario of opportunistic access using an MC-CDMA signal. A differential binary phase shift

keying (DBPSK) transmitter serves as the primary user (carrier frequency = 2.410 GHz, Data rate = 250ksamples/sec) whereas a SS-MC-CDMA transmitter (256 bin FFT, 116 data subcarriers, 2 MHz bandwidth) is the secondary user. The parameters of the secondary user have to be chosen carefully so as not to interfere with primary users. The additional option in SS-MC-CDMA when compared to OFDM is that employing orthogonal codes, we can transmit data of multiple users on the same frequency band around the primary user. As explained earlier, if the CR detects a fairly good channel and wants to eliminate the complexity of coding/decoding, it can collapse to an OFDM system by simply altering the code length to one. Based on the channel criteria, we could also adapt all the various parameters open for reconfiguration, as explained in Section II-B. It is important to note that accuracy in the development of the CM function is vital to the implementation of SS-MC-CDMA with no interference to the incumbent user.

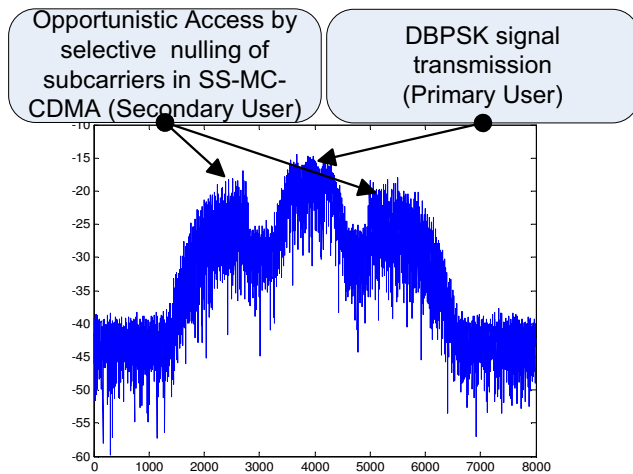

Fig. 9. Real Instance of Spectrum Sharing using MC-CDMA

V. CONCLUSION AND FUTURE WORK

We have highlighted the application of MC-CDMA and its variants to developing highly reconfigurable CR systems. We have analyzed the potential of the SS-MC-CDMA system for Dynamic Spectrum Access and have illustrated an application scenario based on the novel system. With the aid of simulations, we have shown that the nulling of subcarriers does not induce additional error to MC-CDMA systems. In comparison with OFDM, we have shown the improvement in error-resilience as a result of spreading the data. Future work will involve the development of the channel map (CM) function and will focus on establishing parameters derived analytically or empirically by means of real measurements. These would help identify the *triggers* used to switch from one configuration to another in CR. The effect of increasing number of users and MUD in SS-MC-CDMA will also be analyzed in the context of enabling these systems for DSA.

VI. ACKNOWLEDGMENTS

This work is based upon work supported by Science Foundation Ireland under Grant No: 03/CE3/1405 as part of the Centre for Telecommunications Value Chain Research (CTVR), at Trinity College Dublin, Ireland.

REFERENCES

[1] Haykin S., *Cognitive Radio: Brain-Empowered Wireless Communications*, IEEE Journal on Selected Areas in Communications, Feb 2005.

[2] Fazel K. and Kaiser S, *Multi-Carrier and Spread Spectrum Systems*, Wiley, England, 2003.

[3] Yee. N, Linnartz. J and Fettweis. G, *Multi-carrier CDMA for indoor wireless radio networks*, Proc. International Symposium on Personal, Indoor and Mobile Radio Communications (PIMRC'93), Yokohoma, Japan, Pages: 109–113, Sept 1993.

[4] Hara S. and Prasad R. *Overview of Multi-carrier CDMA*, IEEE Transactions on Communications, Pages: 195–198, Volume: 47, Issue: 2, Feb 1999.

[5] Hanzo et al, *Single- and Multi-Carrier DS-SS: Multi-User Detection, Space-Time Spreading, Synchronisation and Standards*, IEEE Press and Wiley, England, 2003.

[6] Hanzo et al, *OFDM and MC-CDMA: for Broadband Multi-User Communications, WLANs and Broadcasting*, IEEE Press and Wiley, England, 2003.

[7] Sarath. D, Nolan. K, Sutton, P.D and Doyle. L.E, *Exploring Reconfigurability Options of Multi-carrier CDMA in Cognitive Radio Systems*, Submitted for review for International Symposium on Personal, Indoor and Mobile Radio Communications (PIMRC'07), to be held in Athens, Greece, Sept 2007.

[8] Choi B-J, Kuan E-L and Hanzo L, *Crest-factor Study of MC-CDMA and OFDM*, Proc. 50th Vehicular Technology Conference (VTC'99), Volume: 1, Pages: 233–237, Netherlands, Sept 1999

[9] Rajbanshi et al., *Comparative Study of Frequency Agile Data Transmission Schemes for Cognitive Radio Transceivers*, 2nd Annual International Wireless Internet Conference - International Workshop on Technology and Policy for Accessing Spectrum (TAPAS'06), Boston, USA, Aug 2006.

[10] Kaiser S and Hoehner P, *Performance of Multi-Carrier CDMA Systems with Channel Estimation in Two Dimensions*, Proc. 8th IEEE International Symposium on Personal, Indoor and Mobile Radio Communications (PIMRC'97), Volume: 1, Pages: 115–119, Sept 1997.

[11] Furudate M, Ishikawa H and Suzuki T, *Evaluation of MC-CDMA with Frequency Interleaving Technique in Frequency Selective Fading Channels*, Special Section on Multi-Carrier Signal Processing Techniques for Next Gen Mobile Communications, The Institute of Electronics, Information and Communication Engineers (IEICE), Volume: E88-B, No. 2, Feb 2005

[12] Yee N. and Linnartz J.P, *Controlled Equalization of Multi-Carrier CDMA in an Indoor Rician Fading Channel*, Proc. 44th Vehicular Technology Conference (VTC'94), Volume:3, Pages: 1665–1669, Jun 1994

[13] Nolan K.E. *Reconfigurable OFDM Systems*, PhD Thesis Trinity College Dublin, Ireland, 2005.

[14] Mackenzie P. *Reconfigurable Software Radio Systems*, PhD Thesis, Trinity College Dublin, Ireland, 2004.

[15] Sutton P., Doyle L. and Nolan K.E., *A Reconfigurable Platform for Cognitive Networks*, Proc. 1st International Conference on Cognitive Radio Oriented Wireless Networks and Communications (CROWNCOM'06), Jun 2006.

[16] Fan P.Z, Darnell M and Honary B *Crosscorrelations of Frank sequences and Chu sequences*, IEEE Electronics Letters, Pages: 477-478, Volume: 30, Issue: 6, Mar 1994.

[17] Failli M and COST 207 Management Committee *Digital Land Mobile Radio Communications : Final Report*, Commission of the European Communities, Luxembourg 1989.

[18] Wu Zhiqiang and Nassar C.R *FD-MC-CDMA: A Frequency-Based Multiple Access Architecture for High Performance Wireless Communications*, IEEE Transactions on Vehicular Technology, Pages: 1392-1399, Volume: 54, No: 4, July 2005.